

# A Constraint on the Number of Distinct Vectors with Application to SLAM

Gilles Chabert and Luc Jaulin

**SWIM'09** June 11th 2009

# Outline

A Constraint  
on the  
Number of  
Distinct  
Vectors with  
Application to  
SLAM

The SLAM  
problem

The NVector  
constraint

Algorithm

Complexity  
issue

- 1 The SLAM problem
- 2 The NVector constraint
- 3 Algorithm
- 4 Complexity issue

# The SLAM problem

A Constraint on the Number of Distinct Vectors with Application to SLAM

The SLAM problem

The NVector constraint

Algorithm

Complexity issue

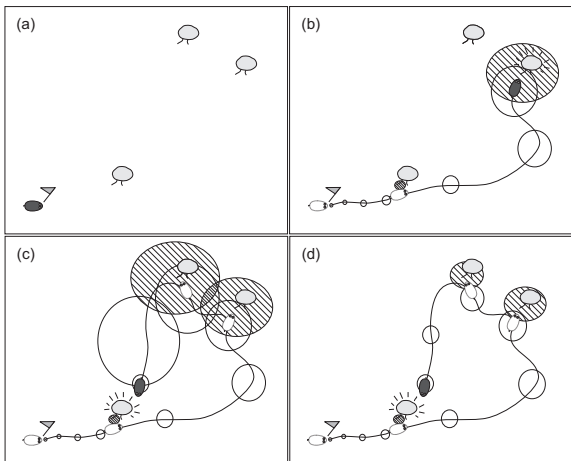

Potential mistakes : omission, illusion, mismatching.

# Outline

A Constraint  
on the  
Number of  
Distinct  
Vectors with  
Application to  
SLAM

The SLAM  
problem

The NVector  
constraint

Algorithm

Complexity  
issue

- 1 The SLAM problem
- 2 The NVector constraint
- 3 Algorithm
- 4 Complexity issue

# The NVector constraint

A Constraint  
on the  
Number of  
Distinct  
Vectors with  
Application to  
SLAM

The SLAM  
problem

The NVector  
constraint

Algorithm

Complexity  
issue

Let  $\mathbf{x}^{(i)}$  be the position of the object corresponding to the  $i^{\text{th}}$  detection.

$$\text{atmost\_nvector}(n, \{\mathbf{x}^{(1)}, \dots, \mathbf{x}^{(k)}\}) \\ \iff |\{\mathbf{x}^{(1)}, \dots, \mathbf{x}^{(k)}\}| \leq n.$$

# The NVector constraint

A Constraint  
on the  
Number of  
Distinct  
Vectors with  
Application to  
SLAM

The SLAM  
problem

The NVector  
constraint

Algorithm

Complexity  
issue

Let  $\mathbf{x}^{(i)}$  be the position of the object corresponding to the  $i^{\text{th}}$  detection.

$$\begin{aligned} \text{atmost\_nvector}(n, \{\mathbf{x}^{(1)}, \dots, \mathbf{x}^{(k)}\}) \\ \iff \\ |\{\mathbf{x}^{(1)}, \dots, \mathbf{x}^{(k)}\}| \leq n. \end{aligned}$$

# The NVector constraint

A Constraint on the Number of Distinct Vectors with Application to SLAM

The SLAM problem

The NVector constraint

Algorithm

Complexity issue

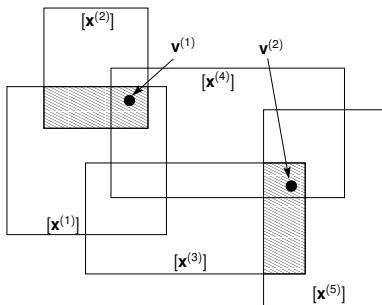

Initial state

# The NVector constraint

A Constraint on the Number of Distinct Vectors with Application to SLAM

The SLAM problem

The NVector constraint

Algorithm

Complexity issue

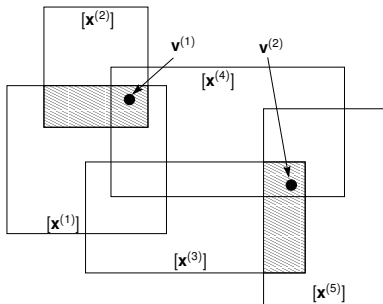

Initial state

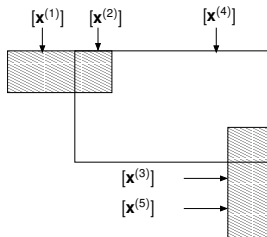

Final state

# Outline

A Constraint  
on the  
Number of  
Distinct  
Vectors with  
Application to  
SLAM

The SLAM  
problem

The NVector  
constraint

Algorithm

Complexity  
issue

- 1 The SLAM problem
- 2 The NVector constraint
- 3 Algorithm**
- 4 Complexity issue

# Algorithm

A Constraint  
on the  
Number of  
Distinct  
Vectors with  
Application to  
SLAM

The SLAM  
problem

The NVector  
constraint

Algorithm

Complexity  
issue

## In one dimension



# Algorithm

A Constraint  
on the  
Number of  
Distinct  
Vectors with  
Application to  
SLAM

The SLAM  
problem

The NVector  
constraint

Algorithm

Complexity  
issue

## In one dimension

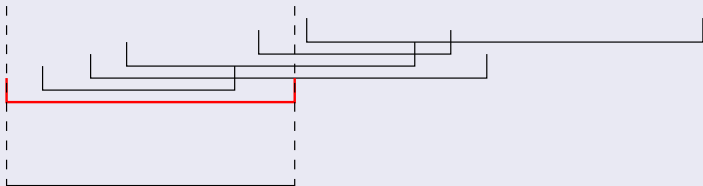

# Algorithm

A Constraint  
on the  
Number of  
Distinct  
Vectors with  
Application to  
SLAM

The SLAM  
problem

The NVector  
constraint

Algorithm

Complexity  
issue

## In one dimension

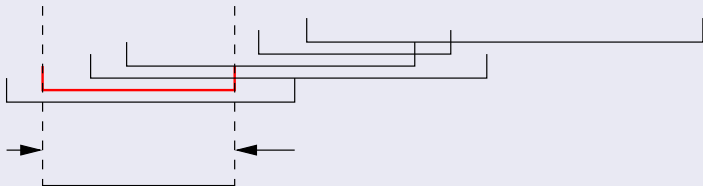

# Algorithm

A Constraint  
on the  
Number of  
Distinct  
Vectors with  
Application to  
SLAM

The SLAM  
problem

The NVector  
constraint

Algorithm

Complexity  
issue

## In one dimension

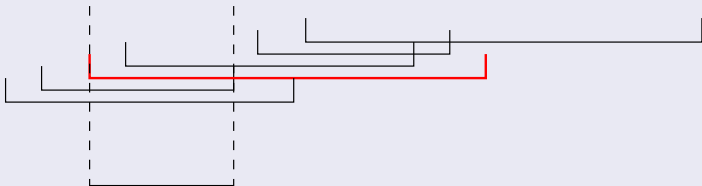



# Algorithm

A Constraint  
on the  
Number of  
Distinct  
Vectors with  
Application to  
SLAM

The SLAM  
problem

The NVector  
constraint

Algorithm

Complexity  
issue

## In one dimension

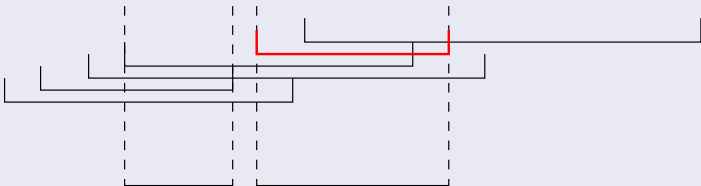

# Algorithm

A Constraint  
on the  
Number of  
Distinct  
Vectors with  
Application to  
SLAM

The SLAM  
problem

The NVector  
constraint

Algorithm

Complexity  
issue

In one dimension

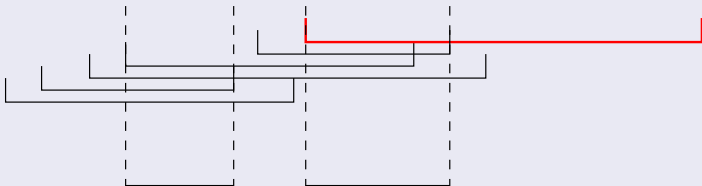

# Algorithm

A Constraint  
on the  
Number of  
Distinct  
Vectors with  
Application to  
SLAM

The SLAM  
problem

The NVector  
constraint

Algorithm

Complexity  
issue

In one dimension

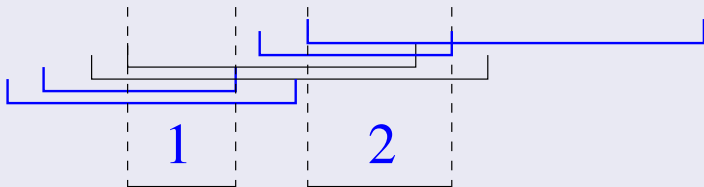

# Algorithm

A Constraint  
on the  
Number of  
Distinct  
Vectors with  
Application to  
SLAM

The SLAM  
problem

The NVector  
constraint

Algorithm

Complexity  
issue

In one dimension

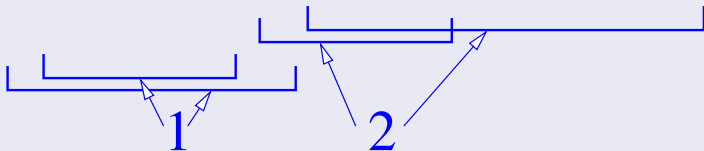

# Algorithm

A Constraint  
on the  
Number of  
Distinct  
Vectors with  
Application to  
SLAM

The SLAM  
problem

The NVector  
constraint

Algorithm

Complexity  
issue

In one dimension

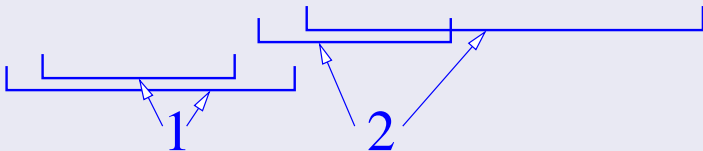

This process can be repeated on every dimension.

# Outline

A Constraint  
on the  
Number of  
Distinct  
Vectors with  
Application to  
SLAM

The SLAM  
problem

The NVector  
constraint

Algorithm

Complexity  
issue

- 1 The SLAM problem
- 2 The NVector constraint
- 3 Algorithm
- 4 Complexity issue

# Complexity issue

A Constraint  
on the  
Number of  
Distinct  
Vectors with  
Application to  
SLAM

The SLAM  
problem

The NVector  
constraint

Algorithm

Complexity  
issue

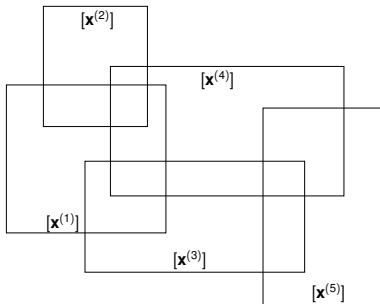

# Complexity issue

A Constraint  
on the  
Number of  
Distinct  
Vectors with  
Application to  
SLAM

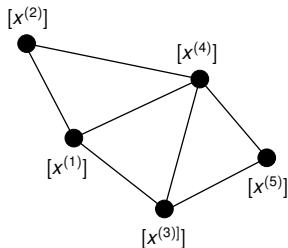
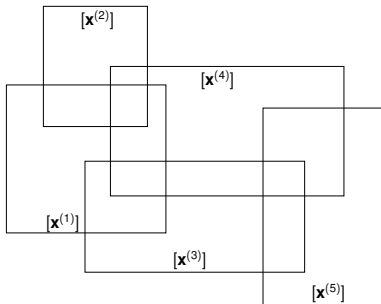

The SLAM  
problem

The NVector  
constraint

Algorithm

Complexity  
issue

# Complexity issue

A Constraint on the Number of Distinct Vectors with Application to SLAM

The SLAM problem

The NVector constraint

Algorithm

Complexity issue

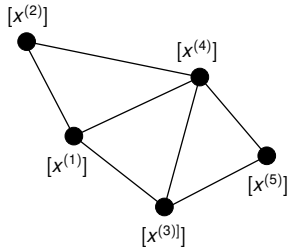
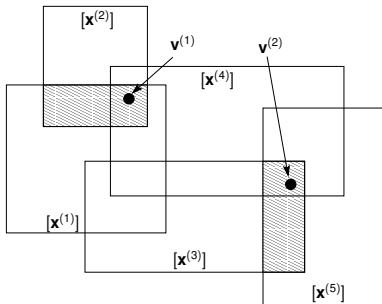

# Complexity issue

A Constraint on the Number of Distinct Vectors with Application to SLAM

The SLAM problem

The NVector constraint

Algorithm

Complexity issue

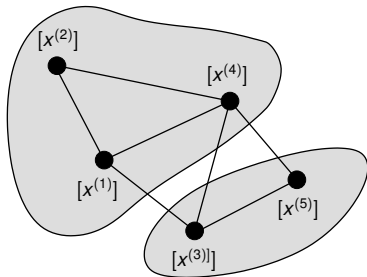
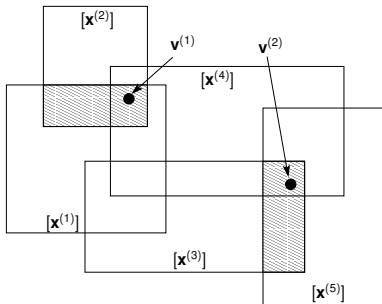

# Complexity issue

A Constraint  
on the  
Number of  
Distinct  
Vectors with  
Application to  
SLAM

The SLAM  
problem

The NVector  
constraint

Algorithm

Complexity  
issue

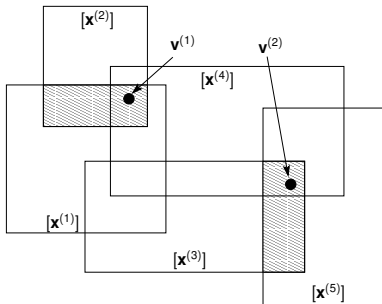

Detections

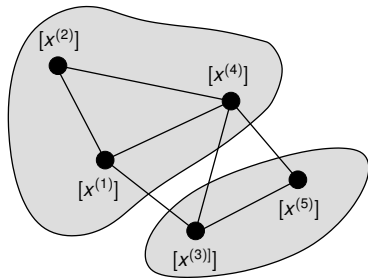

Rectangle graph

# Complexity issue

A Constraint on the Number of Distinct Vectors with Application to SLAM

The SLAM problem

The NVector constraint

Algorithm

Complexity issue

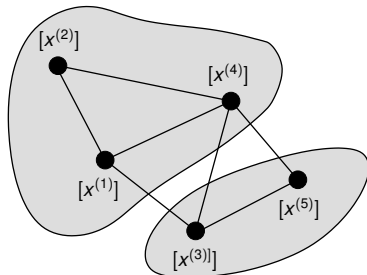
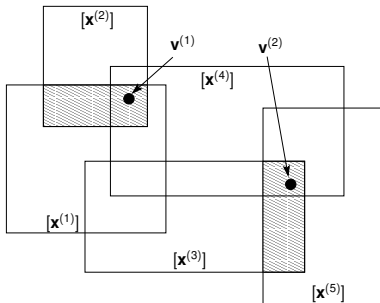

Detections

Rectangle graph

RCP

Can a rectangle graph be partitioned into  $n$  cliques ?

# Complexity issue

A Constraint  
on the  
Number of  
Distinct  
Vectors with  
Application to  
SLAM

The SLAM  
problem

The NVector  
constraint

Algorithm

Complexity  
issue

From planar vertex cover to rectangle clique partition

# Complexity issue

A Constraint  
on the  
Number of  
Distinct  
Vectors with  
Application to  
SLAM

From planar vertex cover to rectangle clique partition

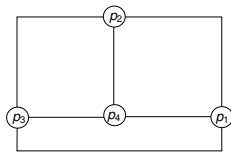
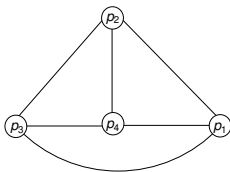
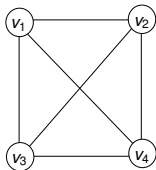

The SLAM  
problem

The NVector  
constraint

Algorithm

Complexity  
issue